

Peregrine Coolant Heater: XP-Type (230V)

Pumped

PEREGRINE XP-type 230V and 415V coolant heaters are fitted with a pump to force heated water around the engine. They are ideally suited to large diesel engines where one, two or more heaters may be needed on a single engine and/or where there is the requirement for alarm operation if the heater or power supply fails.

All XP-type heaters are fitted with twin thermostats set at 50°C adjustable, one operating the heater while the second is set a few degrees lower to switch an independent alarm circuit should the coolant temperature fall below a pre-set temperature.

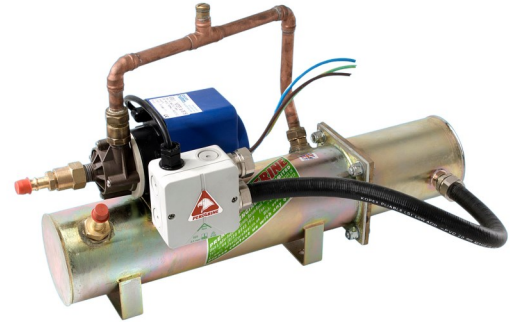

Available in the following size connections:

BSP: ½", ¾", 1"

Model	P4XLP	P5XLP	P6XLP	P7XLP	P8XLPC	P9XLPC	P10XLPC	P11XLPC	P12XLPC	P13XLPC
Wattage	1500	2000	2500	3000	4000	5000	6000	7000	8000	9000
Weatherproof	No									
Voltage	230v AC									
Fluid	Water*/Coolant Mix 50%/50% or specialised coolant									
Connection Options	Hose: 13mm (½"), 19mm (¾")									
Pump Type	35/3, magnetic drive, PPS housing, constant flow									
Heater Body Diameter	101mm									
Heater Body Length	366mm									
Overall Heater Length	431mm				520mm					
Type	Triple element with control thermostat									
Thermostat Range	A45, ranged 35°C - 85°C, set 60°C									
Configuration	Horizontal with 2 x hose connections									
Cable	2m x 2.5 ² single wires with 1676mm flexible Kopex				2m x 4 ² single wires with 1676mm flexible Kopex			2m x 6 ² single wires with 1676mm flexible Kopex		
Heater Finish	Zinc passivated plating									
Supplied	Fixed mountings 9" x 2" x 8mm									

* The use of deionised water will prevent limescale build-up and extend the life of the heater.

Shipping/Warranty Information	
Shipped Dimensions (mm)	620 (L) x 470 (W) x 480 (H)
Shipped Weight	15kg
Warranty	Standard 12 months from delivery



Designed and Built in the UK

+44 (0)20 8848 1912
 sales@preheat.co.uk
 www.preheat.co.uk

PREHEAT
 ENGINEERING LTD

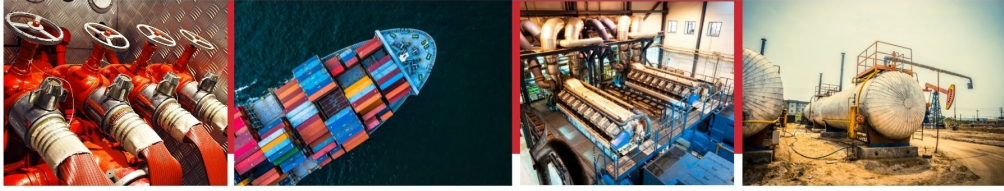

Peregrine Coolant Heater: XP-Type (230V)

Pumped

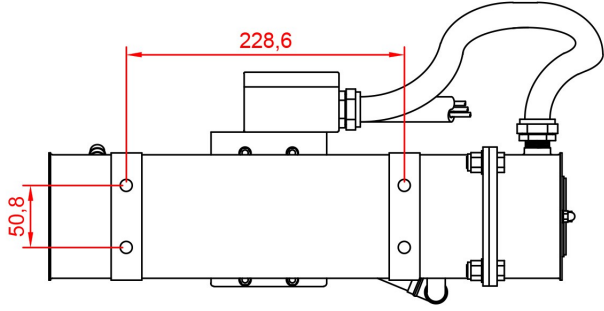
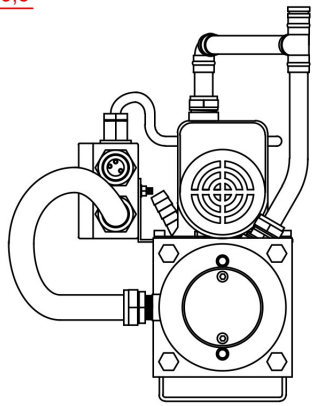
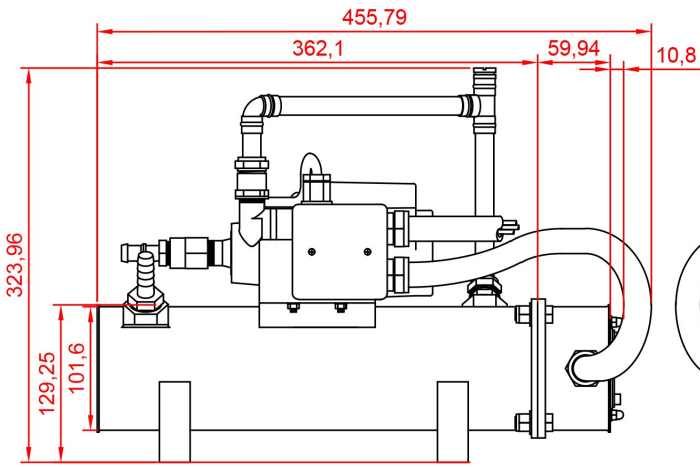
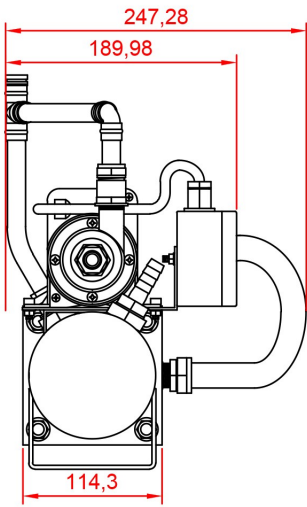
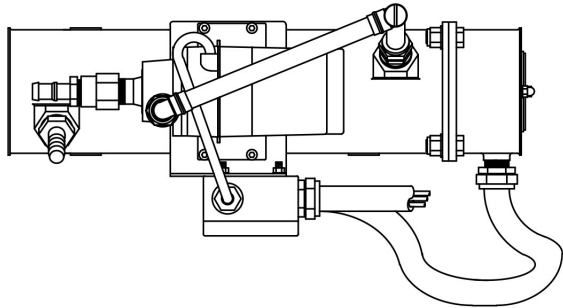

Shipping/Warranty Information	
Shipped Dimensions (mm)	620 (L) x 470 (W) x 480 (H)
Shipped Weight	15kg
Warranty	Standard 12 months from delivery



Designed and Built in the UK

+44 (0)20 8848 1912
 sales@preheat.co.uk
www.preheat.co.uk

