

Peregrine Coolant Heater: X-Type (415V)

PEREGRINE X-type coolant heaters are ideally suited to large diesel engines where one, two or more heaters may be needed on a single engine and/or where there is the need for alarm operation if the heater or supply fails. All X-type heaters are fitted with twin thermostats factory set at 50°C adjustable, one operating the heater while the second is usually set a few degrees lower to switch an independent alarm circuit should the coolant temperature fall below a pre-set temperature.

Available in the following size connections:

Hose: 13mm (½"), 16mm (⅝"), 19mm (¾"), 25.4mm (1"), 31.75mm (1¼")

BSP: 13mm (½"), 19mm (¾"), 25.4mm (1"), 31.75mm (1¼"), 38mm (1.5")



Model	P1XLCZ	P2XLCZ	P4XLCZ	P6XLCZ	P7XLCZ	P9XLCZ	P10XLCZ	P12XLCZ
Wattage	500	750	1500	2250	3000	4500	6000	7500
Weatherproof	No							
Voltage	415v AC							
Fluid	Water*/Coolant Mix 50%/50% or specialised coolant							
Connection Options	Hose: 13mm (½"), 16mm (⅝"), 19mm (¾"), 25.4mm (1"), 31.75mm (1¼") BSP: 13mm (½"), 19mm (¾"), 25.4mm (1"), 31.75mm (1¼"), 38mm (1.5")							
Heater Body Diameter	101mm							
Heater Body Length	296.50mm							
Overall Heater Length	401.25mm							
Type	Triple Element with Control Thermostat and Contactor							
Thermostat Range	A45, ranged 35°C - 85°C, set 50°C							
Configuration	Horizontal/Vertical with 2 x Hose Connections							
Cable	1.5² Single Wires & Kopex				2.5² Single Wires & Kopex			
Heater Finish	Zinc Passivated Plating							
Supplied	Fixed mountings 9" x 2" x 8mm, 1676mm flexible conduit and 20mm adaptor							

* The use of deionised water will prevent limescale build-up and extend the life of the heater.

Shipping/Warranty Information	
Shipped Dimensions (mm)	400 (L) x 260(W) x 160(D)
Shipped Weight	5kg
Warranty	Standard 12 months from delivery



Designed and Built in the UK

+44 (0)20 8848 1912
 sales@preheat.co.uk
 www.preheat.co.uk

PREHEAT
 ENGINEERING LTD

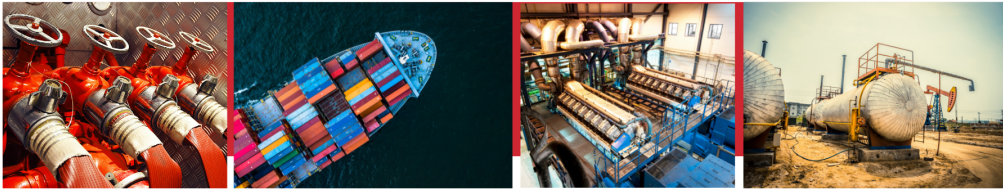

Specification Sheet



PEREGRINE

Peregrine Coolant Heater: X-Type (415V)

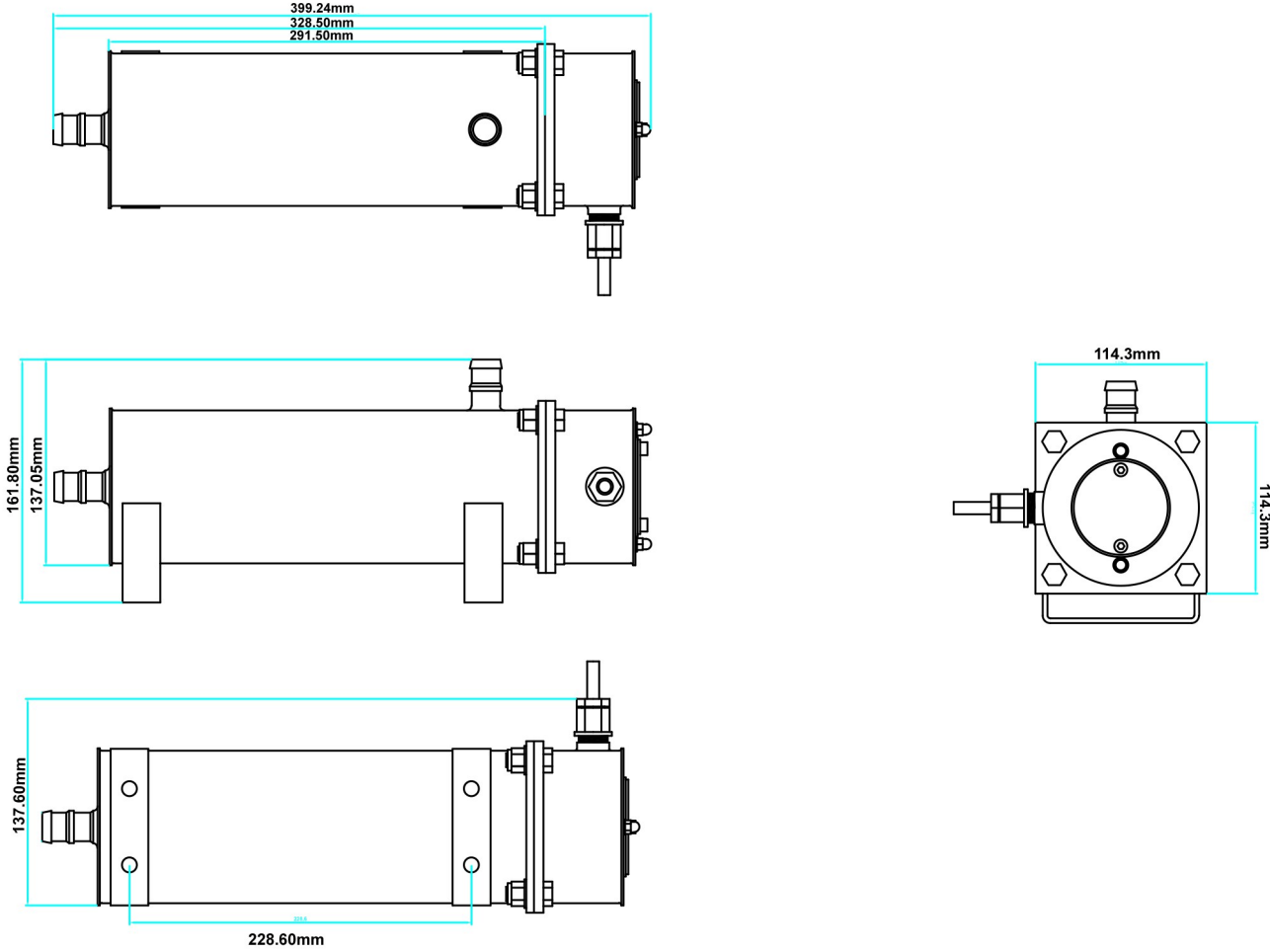

Shipping/Warranty Information	
Shipped Dimensions (mm)	400 (L) x 260(W) x 160(D)
Shipped Weight	5kg
Warranty	Standard 12 months from delivery



Designed and Built in the UK

+44 (0)20 8848 1912
 sales@preheat.co.uk
www.preheat.co.uk

PREHEAT
 ENGINEERING LTD