

# Specification Sheet



## Peregrine Coolant Heater: D-Type

PEREGRINE D-type coolant heaters are thermostatically controlled, twin element heaters with low surface-watts density. They can be fitted vertically or horizontally and are largely used in applications where the extra protection of a second element is needed.

Available in the following size connections:

Hose: 13mm (½”), 16mm (⅝”), 19mm (¾”)

**Full Engine Fitting Kits  
Available**



Model	P1DL	P2DL	P3DL	P4DL	P5DL	P6DL	P7DL
Wattage	500	750	1000	1500	2000	2500	3000
Weatherproof	No						
Voltage	230v AC						
Fluid	Water*/Coolant Mix 50%/50% or specialised coolant						
Connection Options	Hose: 13mm (½”), 16mm (⅝”), 19mm (¾”)						
Heater Body Diameter	63mm						
Heater Body Length	291.50mm						
Overall Heater Length	395.25mm						
Type	Twin Element with Control Thermostat						
Thermostat Range	A45, ranged 35°C - 85°C, set 50°C						
Configuration	Vertical with 2 x Hose Connections						
Cable	2m 0.75² 3-Core Black PVC				2m 1.5² 3-Core Black PVC		
Heater Finish	Zinc Passivated Plating						
Supplied	2 x Mounting Clips and Brackets						

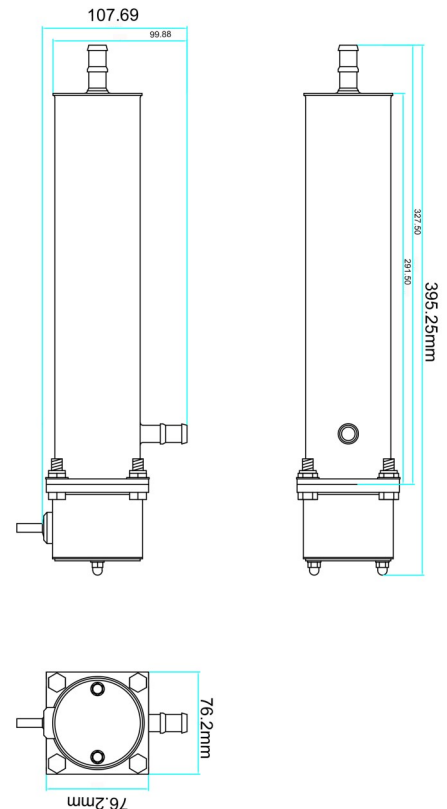

Shipping/Warranty Information	
Shipped Dimensions (mm)	400 (L) x 260(W) x 160(D)
Shipped Weight	3.5kg
Warranty	Standard 12 months from delivery



Designed and Built in the UK

+44 (0)20 8848 1912  
 sales@preheat.co.uk  
[www.preheat.co.uk](http://www.preheat.co.uk)

